

TM 11-5895-1047-23

TECHNICAL MANUAL

**ORGANIZATIONAL AND DIRECT
SUPPORT MAINTENANCE MANUAL
FOR
PLATOON EARLY WARNING SYSTEM**

**AN/TRS-2(V)1 (NSN 5895-01-063-8103)
AN/TRS-2(V)2 (NSN 5895-01-073-9032)
AN/TRS-2(V)3 (NSN 5895-01-063-8104)
AN/TRS-2(V)4 (NSN 5895-01-068-6747)
AN/TRS-2(V)5 (NSN 5895-01-068-6748)
AN/TRS-2(V)6 (NSN 5895-01-068-6749)**

This copy is a reprint which includes current
pages from Changes 1 and 2.

**HEADQUARTERS, DEPARTMENT OF THE ARMY
8 September 1980**

HEADQUARTERS
DEPARTMENT OF THE ARMY
WASHINGTON, DC, 10 September 1982

CHANGE }
No. 2 }

**Organizational and Direct Support
Maintenance Manual**

For

- PLATOON EARLY WARNING SYSTEM**
- AN/TRS-2(V)1 (NSN 5895-01-063-8103)**
- AN/TRS-2(V)2 (NSN 5895-01-073-9032)**
- AN/TRS-2(V)3 (NSN 5895-01-063-8104)**
- AN/TRS-2(V)4 (NSN 5895-01-068-6747)**
- AN/TRS-2(V)5 (NSN 5895-01-068-6748)**
- AN/TRS-2(V)6 (NSN 5895-01-068-6749)**

TM 11-5895-1047-23, 8 September 1980, is changed as follows:

1. New or changed material is indicated by a vertical bar in the margin of the page.
2. Added or revised illustrations are indicated by a vertical bar in front of the figure caption.
3. Remove and insert pages as indicated below:

<i>Remove</i>	<i>Insert</i>
i and ii	i and ii
1-1	1-1
3-3 through 3-6	3-3 through 3-6
3-9 through 3-12	3-9 through 3-12
A-1	A-1
B-3 through B-6	B-3 through B-6

4. File this change sheet in front of the publication for reference purposes.

By Order of the Secretary of the Army:

E. C. MEYER
General, United States Army
Chief of Staff

Official:

ROBERT M. JOYCE
Brigadier General, United States Army
The Adjutant General

Distribution:

To be distributed in accordance with Special Mailing List.

Change }
No. 1 }

HEADQUARTERS
DEPARTMENT OF THE ARMY
Washington, DC, 24 July 1981

**Organizational and Direct Support
Maintenance Manual
PLATOON EARLY WARNING SYSTEM
AN/TRS-2(V)1 (NSN 5895-01-063-8103)
AN/TRS-2(V)2 (NSN 5895-01-073-9032)
AN/TRS-2(V)3 (NSN 5895-01-063-8104)
AN/TRS-2(V)4 (NSN 5895-01-068-6747)
AN/TRS-2(V)5 (NSN 5895-01-068-6748)
AN/TRS-2(V)6 (NSN 5895-01-068-6749)**

TM 11-5895-1047-23, 8 September 1980, is changed as follows:

- 1. New or changed material is indicated by a vertical bar in the margin.
- 2. Remove and insert pages as indicated below:

<i>Remove</i>	<i>Insert</i>
2-1 Through 2-6	2-1 through 2-3
B-3 and B-4.B-3 and B-4

- 3. File this change sheet in front of the manual for reference purposes.

By Order of the Secretary of the Army:

E. C. MEYER
*General, United States Army
Chief of Staff*

Official:

ROBERT M. JOYCE
*Brigadier General, United States Army
The Adjutant General*

Distribution:

Active Army:

HISA (Ft Monmouth) (15)
USAINCSCOM (2)
COE (1)
TSC (1)
USAARENBD (1)
DARCOM (1)
TRADOC (2)
OS MAJ COMD (4)
TECOM (2)
USACC (2)
MDW (1)
Armies Corps (2)
Corps (2)
Svc Colleges
USASICS (5)
USAADS (2)
USAFAS (2)
USAARMS (2)
USAIS (2)

USAES (2)
USAICS (2)
USAES (2)
USAICS (3)
MAAG (1)
USARMIS (1)
USAERDM (1)
USAERDAW (1)
Ft Carson (5)
Ft Cillem (10)
Ft Cordon (10)
Ft Richardson (CERCOM Ofc) (2)
Army Dep (1) except
SAAD (30)
SHAD (2)
TOAD (14)
USA Dep (1)
Sig Sec USA Dep (1)
Units org under fol TOE:
29-207 (2)
29-610 (2)

NG: State AC (0); Units-None

USAR: None

For explanation of abbreviations used, see AR 310-50.

WARNING

HIGH VOLTAGE

is used in the associated test equipments.

DEATH ON CONTACT

MAY RESULT IF SAFETY PRECAUTIONS

ARE NOT OBSERVED.

Maintenance adjustments of this equipment are made with power applied. Be careful when working near the interior of the equipment or near the ac power distribution wiring.

WARNING

Adequate ventilation should be provided while using TRICHLOROTRIFLUOROETHANE. Prolonged breathing of vapor should be avoided. The solvent should not be used near heat or open flame; the products of decomposition are toxic and irritating. Since TRICHLOROTRIFLUOROETHANE dissolves natural oils, prolonged contact with skin should be avoided. When necessary, use gloves which the solvent cannot penetrate. If the solvent is taken internally, consult a physician immediately.

ORGANIZATIONAL AND DIRECT SUPPORT MAINTENANCE MANUAL FOR PLATOON EARLY WARNING SYSTEM

- AN/TRS-2(V) 1 (NSN 5895-01-063-8103)
- AN/TRS-2(V) 2 (NSN 5895-01-073-9032)
- AN/TRS-2(V) 3 (NSN 5895-01-063-8104)
- AN/TRS-2(V) 4 (NSN 5895-01-088-6747)
- AN/TRS-2(V) 5 (NSN 5895-01-068-6748)
- AN/TRS-2(V) 6 (NSN 5895-01-068-6749)

REPORTING ERRORS AND RECOMMENDING IMPROVEMENTS

You can help improve this manual. If you find any mistakes or if you know of a way to improve the procedures, please let us know. Mail your letter, DA Form 2028 (Recommended Changes to Publications and Blank Forms), or DA Form 2028-2 located in back of this manual direct to Commander, US Army Communications - Electronics Command, ATTN: DRSEL-ME-MQ, Fort Monmouth, NJ 07703. A reply will be furnished direct to you.

TABLE OF CONTENTS

		Paragraph	Page
CHAPTER	1. INTRODUCTION		
Section	I. General		
	Scope	1-1	1-1
	Maintenance Forms, Records, and Reports	1-2	1-1
	Index of Technical Publications	1-2.1	1-1
	Destruction of Army Electronic Material to Prevent Enemy Use	1-3	1-1
	Administrative Storage	1-4	1-1
	Reporting Equipment Improvement Recommendation (EIR)	1-5	1-1
Section	II. Description and Data		
	Description	1-6	1-1
	Tabulated Data	1-7	1-1
CHAPTER	2. FUNCTIONING OF EQUIPMENT		
	General Information	2-1	2-1
	System Modes of Operation	2-2	2-1
	Functioning of Detector, Anti-Intrusion DT-577(V)/TRS-2(V)	2-3	2-1
	Selection of Detector Area and ID Numbers	2-4	2-1
	Function of Receiver, Radio R-1808(V)/TRS-2(V)	2-5	2-5
	Functioning of Sensor Interface, Wire Link MX-9738/TRS-2(V)	2-6	2-6
CHAPTER	3. DIRECT SUPPORT MAINTENANCE INSTRUCTIONS		
Section	I. General		
	Introduction	3-1	3-1
	Tools and Equipment	3-2	3-1

			Paragraph	Page
SECTION	II.	Troubleshooting		
		Troubleshooting Detector, Anti-Intrusion DT-577(V)/TRS-2(V)	3-3	3-1
		Troubleshooting Receiver, Radio R-1808(V)/TRS-2(V)	3-4	3-3
		Troubleshooting Sensor Interface, Wire Link MX-9738/TRS-2(V)	3-5	3-9
SECTION	III.	Maintenance of AN/TRS-2(V) through 6 (PEWS)		
		Maintenance of Detector, Anti-Intrusion DT-577(V)/TRS-2(V)	3-6	3-10
		Maintenance of Receiver, Radio R-1808(V)/TRS-2(V)	3-7	3-13
		Maintenance of Sensor Interface, Wire Link MX-9738/TRS-2(V)	3-8	3-14
SECTION	IV.	Direct Support Testing Procedures		
		Permission Tests	3-9	3-14
		Detector, Anti-Intrusion DT-577(V)/TRS-2(V) Acceptance Test	3-10	3-14
APPENDIX	A.	REFERENCES		A-1
APPENDIX	B.	MAINTENANCE ALLOCATION		
SECTION	I.	Introduction		B-1
	II.	Maintenance Allocation Chart		B-3
	III.	Tool and Test Equipment Requirements		B-4
	IV.	Remarks		B-5
APPENDIX	C.	EXPENDABLE SUPPLIES AND MATERIALS LIST		
SECTION	I.	Introduction		C-1
	II.	Expendable Supplies and Materials List		C-3

LIST OF ILLUSTRATIONS

<i>FIGURE</i>	<i>TITLE</i>	<i>PAGE</i>
2-1	PEWS Block Diagram	2-2
2-2	Detector Block Diagram	2-3
2-3	Receiver Block Diagram	2-4
2-4	Wire Link Block Diagram	2-6
3-1	Detector Current Drain Test	3-2
3-2	Frequency Measurement Setup	3-4
3-3	Receiver Sensitivity and Display Test Setup	3-5
3-4	Example Data Switch Settings, Test Set, Receiver TS-3565/TRS-2(V)	3-7
3-5	Wire Link Test Setup	3-9
3-6	Detector, Code Plug Assembly	3-10
3-7	Code Plug Area Connections	3-11
3-8	Code Plug ID Connections	3-13

CHAPTER 1 INTRODUCTION

Section I. General

1-1. Scope

a. This manual contains information pertinent to organizational and direct support maintenance of the Platoon Early Warning System (PEWS), AN/TRS-2(V)1 thru 6. It includes a functional description of the system, instructions for equipment testing, troubleshooting and maintenance procedures. Appendix A provides you with references to other applicable manuals.

b. Throughout this manual references are made to the six variations of the PEWS. This also applies to the Receiver, Radio R-1808 (V)/TRS-2(V) and Detector, Anti-Intrusion DT-577(V)/TRS-2(V).

AN/TRS-2(V)1 R-1808 (V)1/TRS-2(V) DT-577(V)1/
TRS-2(V) 139.100 MHz

AN/TRS-2(V)2 R-1808(V)2/TRS-2(V) DT-577(V)2/
TRS-2(V) 139.250 MHz

AN/TRS-2(V)3 R-1808(V)3/TRS-2(V) DT-577(V)3/
TRS-2(V) 141.100 MHz

AN/TRS-2(V)4 R-1808(V)4/TRS-2(V) DT-577(V)4/
TRS-2(V) 148.925 MHz

AN/TRS-2(V)5 R-1808 (V)5/TRS-2(V) DT-577(V)5/
TRS-2(V) 149.600 MHz

AN/TRS-2(V)6 R-1808 (V)6/TRS-2(V) DT-577(V)6/
TRS-2(V) 150.600 MHz

Unless otherwise specified references to the AN/TRS-2(V), R-1808(V)/TRS-2(V), and DT-577(V)/TRS-2(V) apply to all variations.

1-2. Maintenance Forms, Records, and Reports

a. *Reports of Maintenance and Unsatisfactory Equipment.* Department of the Army forms and procedures used for equipment maintenance will be those prescribed by TM 38-750, The Army Maintenance Management System.

b. *Report of Packaging and Handling Deficiencies.* Fill out and forward SF 364 (Report of Discrepancy (ROD)) as prescribed in AR-735-11-2/DLAR 4140.55/NAVMATINST 4355.73/AFR 400.54/MCO 4430.3E. ,

c. *Discrepancy in Shipment Report (DISREP) (SF 361).* Fill out and forward Discrepancy in Shipment Report (DISREP) (SF 361) as prescribed in AR 55-38/NAVSUPINST 4610.33B/AFR 75-18/MCO P4610.19C/DLAR 4500.15.

1-2.1. Index of Technical Publications

Refer to the latest issue of DA Pam 310-4 to determine whether there are new editions, changes or additional publications pertaining to the equipment.

1-3. Destruction of Army Electronics Materiel to Prevent Enemy Use

Destruction of electronics materiel to prevent enemy use shall be in accordance with TM 750-244-2.

1-4. Administrative Storage

For procedures, forms, records, and inspections required during administrative storage of this equipment refer to TM 740-90-1.

1-5. Reporting Equipment Improvement Recommendations (EIR)

If your Platoon Early Warning System AN/TRS-2(V)1 through AN/TRS-2(V)6 needs improvement, let us know. Send us an EIR. You, the user, are the only one who can tell us what you don't like about your equipment. Let us know why you don't like the design. Tell us why a procedure is hard to perform. Put it on an SF 368 (Quality Deficiency Report). Mail it to Commander, US Army Communications-Electronics Command, ATTN: DRSEL-ME-MQ, Fort Monmouth, New Jersey 07703. We'll send you a reply.

Section II. DESCRIPTION AND DATA

1-6. Description

A general description and illustrations of the AN/TRS-2(V)1 thru 6 are contained in the PEWS Operator's Manual, TM 11-5895-1047-10.

1-7. Tabulated Data

Tabulated data for the AN/TRS-2(V)1 thru 6 are contained in the Operator's Manual, TM 11-5895-1047-10, Chapter 1.

CHAPTER 2

FUNCTIONING OF EQUIPMENT

2-1. General Information

This chapter explains how the equipment functions on a block diagram level. The explanation starts with the system block diagram, and then describes each individual operating component in turn.

2-2. System Modes of Operation

(fig. 2-1)

The PEWS has two modes of operation. The modes are depicted in the block diagram.

a. RF Mode. Detector, Anti-Intrusion DT-577(V)/TRS-2(V) (detector), and Receiver, Radio R-1808 (V)/TRS-2(V) (receiver) are used in the RF mode. In operation, the detector senses the presence of an intruder and determines whether it is a person or vehicle. The detector then transmits a frequency modulated (fm) radio frequency (rf) signal which contains its number and a code for the type of intruder that has been sensed. The rf signal is detected by the receiver. The receiver when processes the rf signal and displays the number and intruder code from the detector.

b. Wire Mode. In the wire mode, when the detector senses an intruder, a signal is transmitted to the receiver on field wire. Sensor Interface, Link MX-9738/TRS-2(V) (wire link) is attached to the receiver and provides connections for the field wire. The receiver displays the detector number and the intruder code as in the rf mode.

2-3. Functioning of Detector, Anti-Intrusion DT-577(V)/TRS-2(V)

(fig. 2-2)

a. Detector Activation. The detector contains a magnetic sensor and a seismic sensor. The magnetic sensor is activated by changes in the earth's magnetic field caused by the movement of vehicles. The seismic sensor is activated by vibrations transmitted through the ground and usually caused by personnel or vehicle movements.

b. Seismic Signal. The seismic signal is generated in the seismic sensor. It is a low frequency, analog signal, generated from ground displacements (vibrations) caused by footsteps or vehicle movements. This signal is sent to the seismic sensor processor where it is converted to a digital signal and timed to determine whether it represents a vehicle (C) or footsteps (P). This C or P signal is

sent to the classification logic for processing with the magnetic signal.

c. Magnetic Signal. The magnetic signal is generated in the magnetic sensor from changes in the earth's magnetic field that surrounds the detector. The signal is amplified and applied to the threshold logic. If the signal is large enough, it will overcome threshold and generate a digital signal (C). The C signal is sent to the classification logic.

d. Classification Logic. There are 3 signal inputs to the classification logic: the magnet signal, the seismic signal, and an input from the test switch. The output from the classification logic is the code for either C (vehicle) or P (personnel) depending on the input. A P coded seismic input signal produces a P output from the classification logic. However, a C coded seismic signal will only produce a C output from the classification logic when there is also a magnetic signal (C) input. The test switch, when pushed, produces either Corp (random) output to the encoder for testing purposes.

e. Encoder. The encoder is triggered by either a C or P output from the classification logic. Wire It produces a 10 bit digital signal which is used to key the frequency modulation (FM) transmitter and the line driver. A code plug, which is preset to designate an area number, detector number (ID number), and a parity digit, is a fixed input to the encoder.

f. RF Mode. In the RF mode of operation, the power switch is placed to the RF position. This applies the 9 vdc battery to the FM transmitter and all other circuits except the line driver. Then when the encoder generates a digital signal, the FM transmitter transmits and the antenna radiates the signal.

g. Wire Mode. In the wire mode of operation, the power switch is placed in the WIRE position. This applies the 9 vdc battery to the line driver and all other circuits except the FM transmitter. Now when the encoder generates a digital signal, the line driver is turned on and a frequency shift keying (FSK) signal is sent on field wire to the receiver.

h. Detector Signal The signal transmitted by the detector (either radio or wire) contains information in digital form. It is a digital message containing 10 time slots or bits as follows:

- Start Code 1 bit
- Area Code 3 bits (8 possible numbers)
- ID Code 4 bits (16 possible numbers)
- Parity Code 1 bit (odd parity)
- Classification Code 1 bit (C or P)

2-4. Selection of Detector Area and 10 Numbers

a. Detectors are identified by their ID number. Each detector in a system should be numbered individually so that when a signal is received, the intruder position can be located on the detector deployment map.

b. The area number code of a detector may be used to separate detectors into groups. This is done by using a different area number in each group. The different area number allows the system receiver to select detector signals from one group while excluding the other group. Normally all detectors in the same system use the same area number.

2-5. Functioning of Receiver, Radio R-1808(V)/TRS-2(V)

(fig.2-3)

a. RF Circuit Card. The rf circuit card performs three functions in the operation of the receiver.

(1) Voltage regulation and low battery detection functions are handled by components mounted on the rf circuit card. Regulated power supply voltage is used throughout the receiver. The low battery detection circuit output is applied to the memory/display circuit card to activate the display when the battery is low.

(2) In the RF mode of operation, the RF signal from the antenna is processed by circuits on the RF circuit card. The RF signal is converted to an intermediate frequency signal, amplified, and applied to an FM discriminator. The output signal from the FM discriminator is an FSK signal which contains the digital signal from the detector.

(3) In the wire mode and the RF mode of operation, the FKS detector is used to produce a digital signal (data) output to the decoder circuit card.

b. Decoder Circuit Card. The decoder circuit card has two inputs and three outputs.

(1) The first input is the data signal from the FSK detector. The second input is from the AREA selector switch. When a detector signal is received, the area code portion of the digital signal is compared to the AREA selector switch setting. If they are different the data signal goes

no further. If they are the same, outputs are sent to the memory/display card.

(2) The outputs from the decoder circuit card are: the data signal, which now contains only the detector number and the intruder code; the enable signal, which is produced if there are the proper number digits (parity) in the data signals and the clock signal which is generated in the decoder and used in decoding the data signals.

c. Memory /Display Circuit Card. The memory/display circuit card is the control for the receiver display and the audio tone for the earphone. The input signals for the memory/display circuit card are: the data signal, the enable signal, the clock signal, and the input when the TEST-RESET switch is pushed.

(1) The data signal contains the detector number and the C or P code. This signal is decoded and displayed if an enable signal is also received. The detector number and the C or P code is also entered into memory if it has not been entered previously. When this happens a new data indicator appears on the display and a tone is generated in the earphone.

(2) The clock signal is used for timing and control of the memory/display circuit card. It controls the length of time the display is on, controls the sequential display of the detector numbers in memory. And, it is used to generate the tone signal heard in the earphone.

(3) The TEST-RESET switch input signal provides two functions. When pressed, all detector numbers and intruder codes stored in memory are removed. At the same time, all indicator segments in the display are activated, and a tone signal is activated. This is used to test the receiver's indicators.

2-6. Functioning of Sensor Interface, Wire Link MX-9738/TRS-2(V)

(fig. 2-4)

The wire link is used to terminate the field wire lines from the detectors, to test the lines, and to amplify and condition the input signals. Power to operate the wire link comes from the receiver.

a. The rotary test switch contains 10 positions: nine for line testing and one for operation (REC). In the testing positions, each individual line connected to the line test circuit. The line to circuit tests the line for a short or open condition. If either one of these conditions occur, a light emitting diode (LED) will light.

b. When the rotary test switch is in the RF position, all lines are connected to the differential amplifier and level detector. Detector signals,

received on the lines, are filtered and amplified by the differential amplifier and then fed to the level detector. The level detector amplifies any signal above a set level. Once above the set level the signal is squared up to eliminate noise modulation.

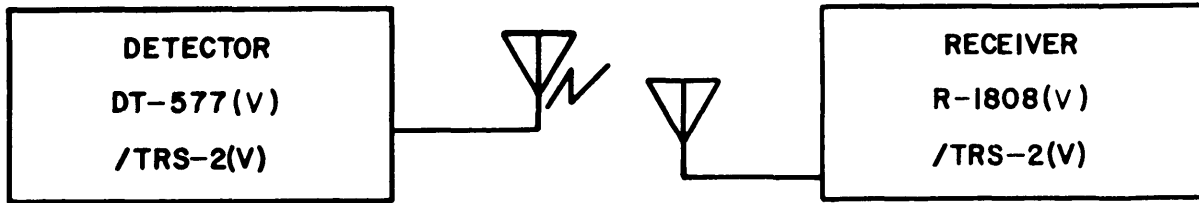

A. BLOCK DIAGRAM RF MODE

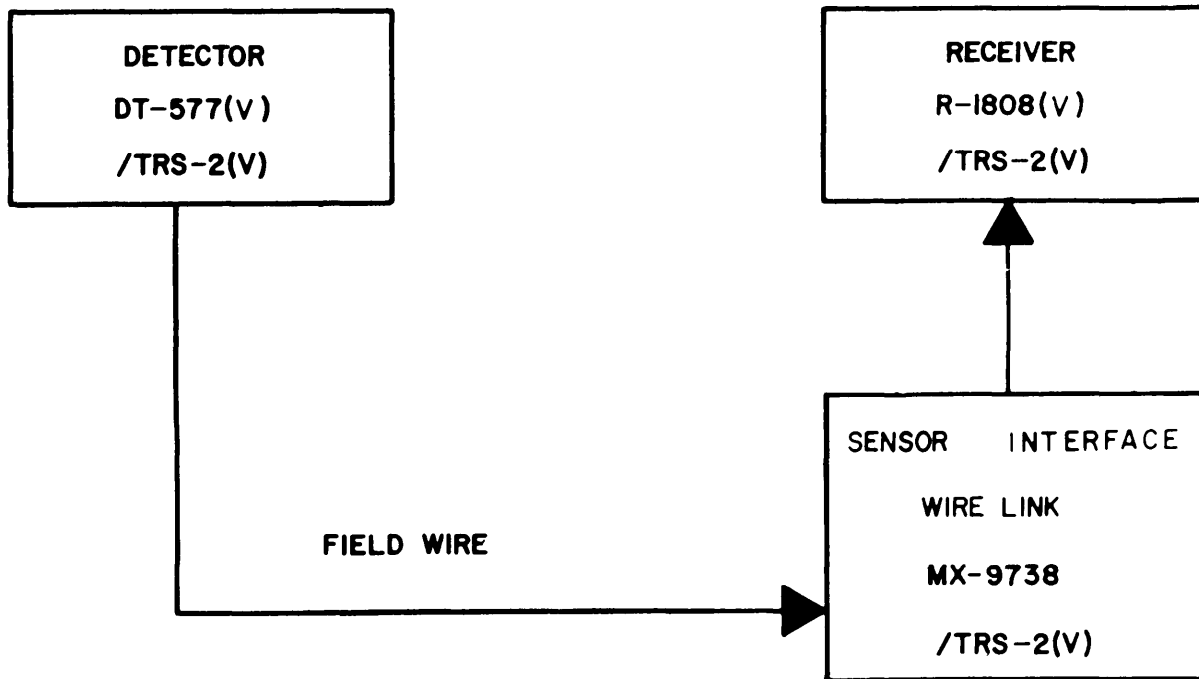

FIGURE 2-1 B. BLOCK DIAGRAM WIRE MODE

EL 5UL001 -

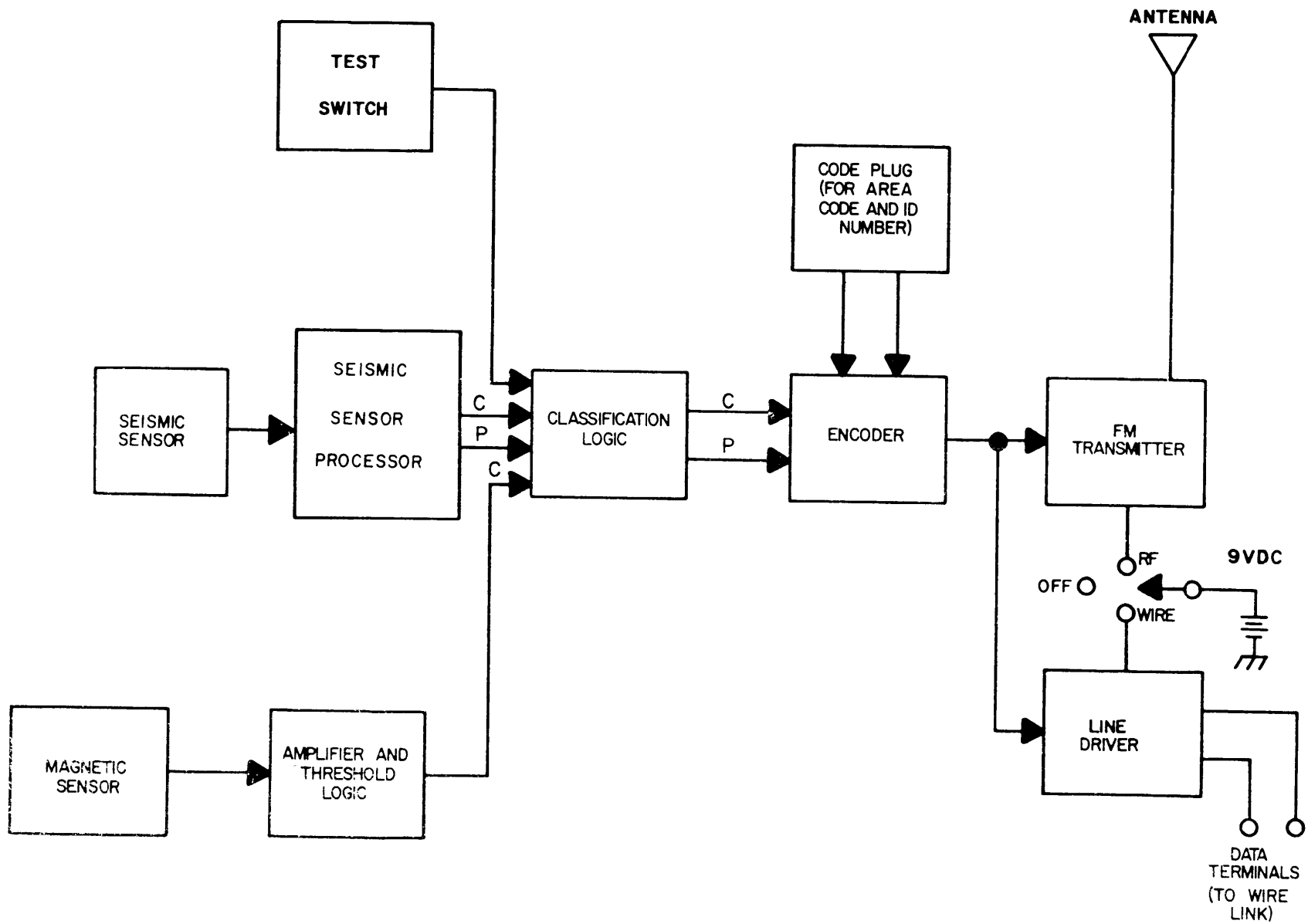
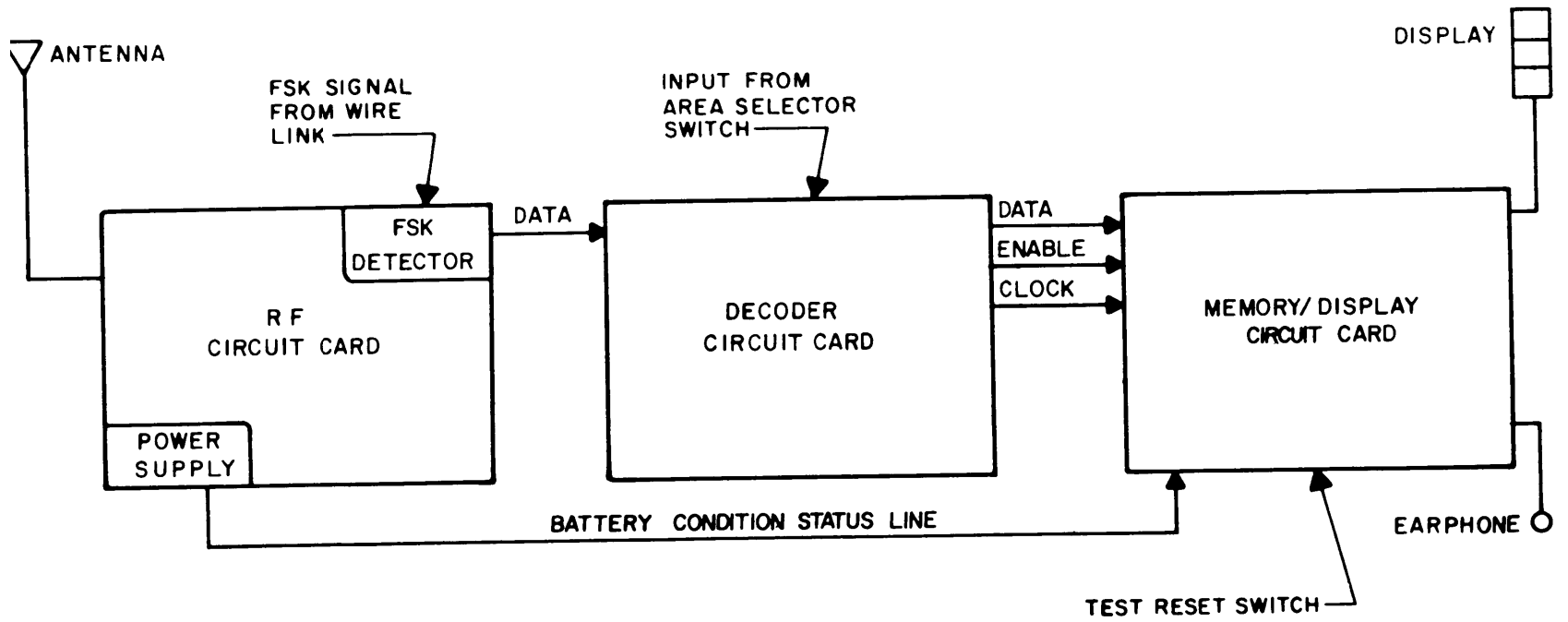
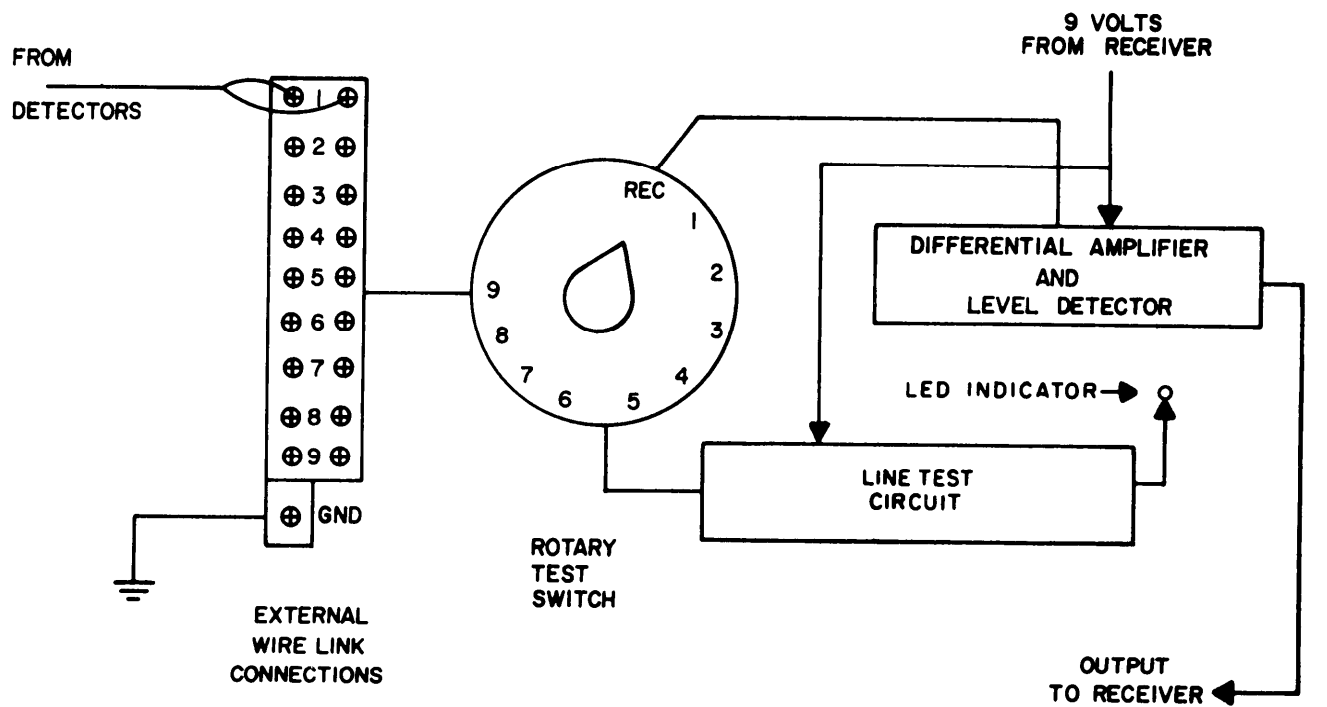

Figure 2-2. Detector Block Diagram.

Figure 2-3. Receiver Block Diagram.





EL5ULO04

Figure 2-4. Wire Link Block Diagram.

CHAPTER 3

DIRECT SUPPORT MAINTENANCE INSTRUCTIONS

Section I. General

3-1. Introduction.

Troubleshooting procedures localize faults to a defective component. The repair and replacement procedures give step by step instructions on the repair and/or replacement of faulty components. The direct support testing procedures listed in this chapter are used as an overall check of system serviceability. These supplement the instructions described in TM 11-5895-1047-10.

3-2. Tools and Equipment.

Repair parts, special tools, and special test equipment authorized for direct support maintenance are listed in TM 11-5895-1047-23P, the Repair Parts and Special Tools List for the AN/TRS-2(V). The following equip-

ment is required for maintenance.

TOOLS/TEST EQUIPMENT	NATIONAL STOCK NUMBER
1. Tool Kit, Electronic Equipment TK-105/G	5180-00-610-5177
2. Test Set, Receiver TS-3565/TRS-2	6625-01-075-0046
3. Signal Generator AN/URM-70	6625-00-519-2104
4. Multimeter TS-352B/U	6625-00-553-0142
5. Counter, Electronic, Digital Readout AN/USM-207	6625-00-911-6368

Section II. TROUBLESHOOTING

3-3. Troubleshooting Detector, Anti-Intrusion DT-577(V)/TRS-2(V).

a. The following procedures measure current drain of detector transmissions in the wire and the RF modes of operation.

b. Current Drain Test. Multimeter TS-352/U is utilized for this test. Multimeter should be set to measure DC

milliamperes. For information on the multimeter refer to TM 114625-36615.

(1) Set detector toggle switch to OFF. Remove battery cover and disconnect battery. Install multimeter in series with battery, and detector battery connector, as shown in figure 3-1, and perform the following current drain tests:

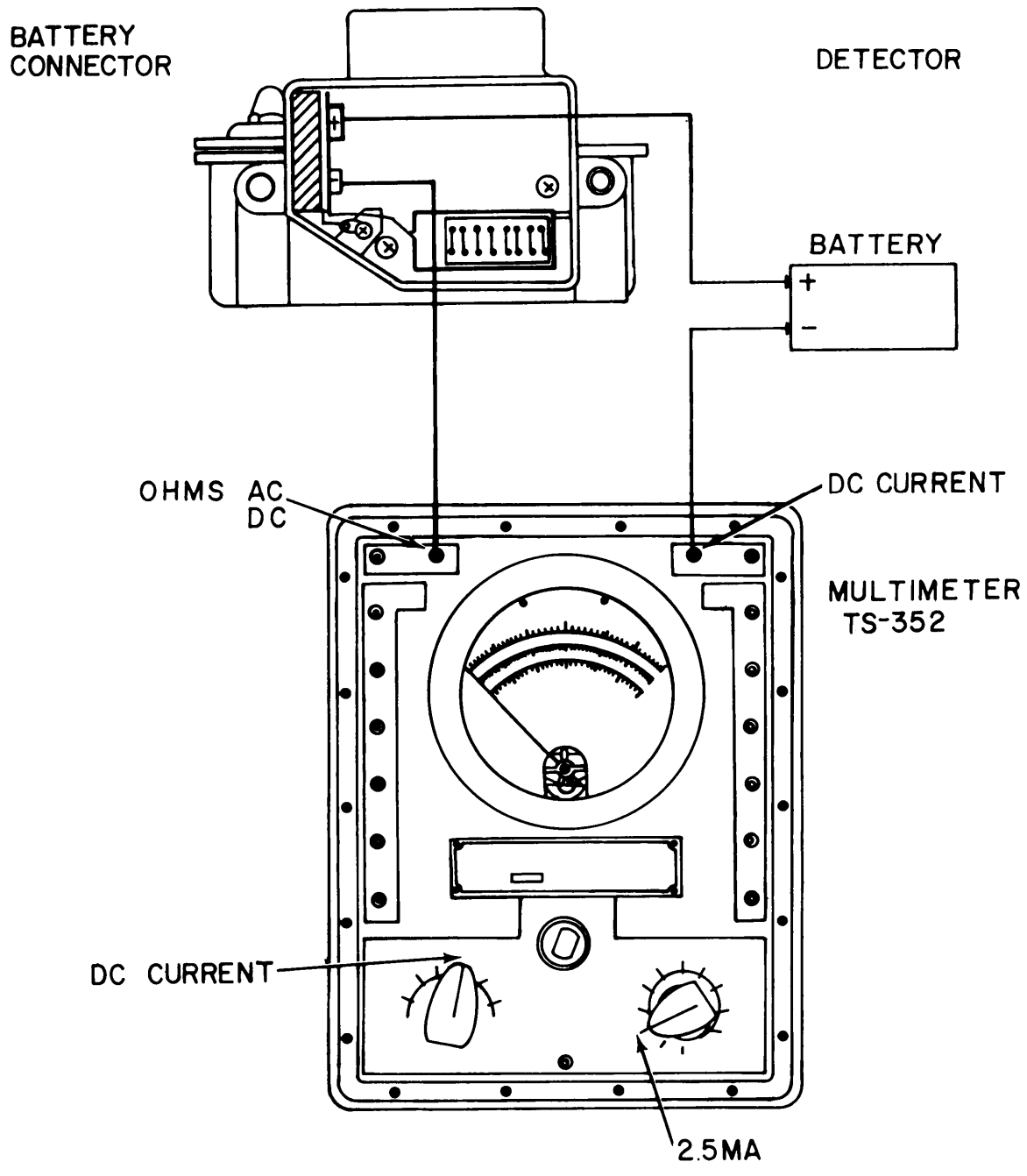

EL5UL005

Figure 3-1. Detector Current Drain Test.

- (2) Set detector toggle switch to W and note the amount of current drain (1.0 mA maximum).
- (3) Set detector toggle switch to OFF, then to RF (there will be a momentary current surge) and note the amount of current drain (1.0 mA maximum).
- (4) Press detector test button and observe the RF Transmit mode current surge.
- (5) Turn off detector and multimeter. Disconnect test leads. Replace detector battery and cover.

3-4. Troubleshooting Receiver, Radio R-1808(V)/TRS-2(V)

The following tests are performed to check the sensitivity and display outputs of the PEWS receiver. Test Set, Receiver TS-3565/TRS-2(V) is utilized for these tests. For information on the test set, refer to TM 11-6625-2784-14.

NOTE

Before performing any tests, the signal generator should be allowed to warm up for approximately two hours.

a. Preliminary Procedures and Adjustments.

- (1) Place the test set on the bench and unfasten the latches which hold the cover on the test set.
- (2) Remove the cable assemblies stored in the cover of the test set.
- (3) Position the receiver to be tested, Signal Generator AN/URM-70, and Electronic Counter AN/USM-207 on the test bench. Using the rf cable, connect the output of the signal generator to the electronic counter as shown in Figure 3-2.

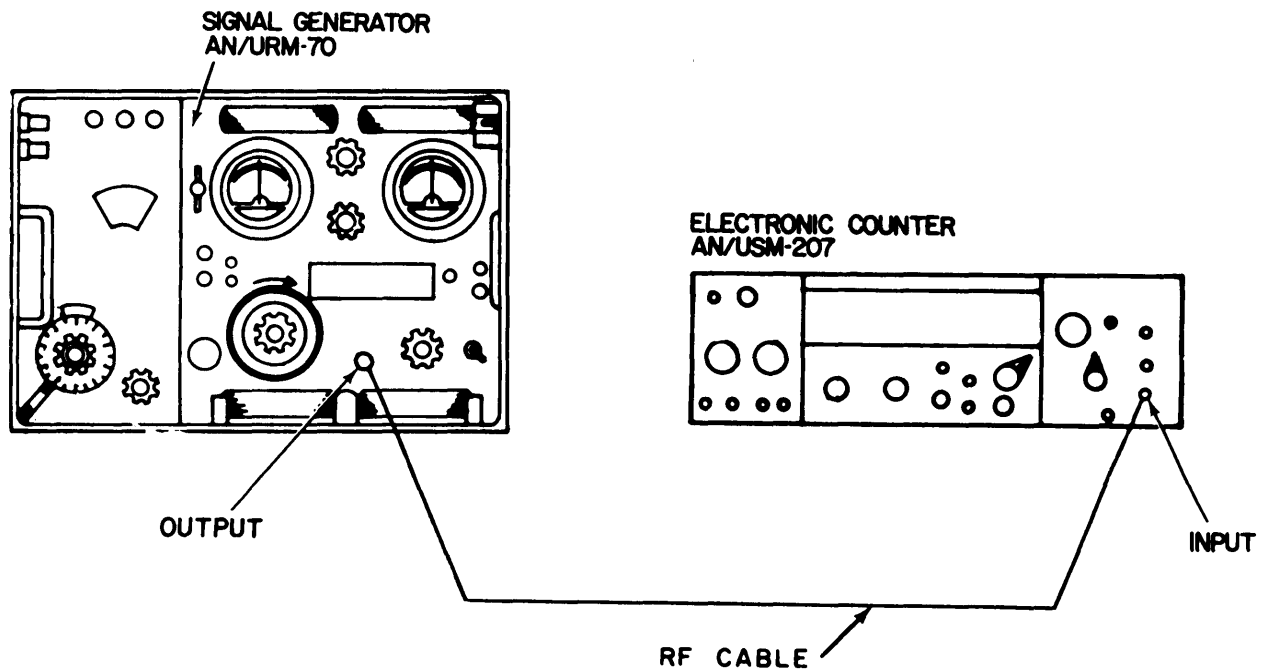

EL5UL206

Figure 3-2. Frequency Measurement Setup.

TM 11-5895-1047-23

(4) Set the controls of Signal Generator AN/URM-70 as follows:

<i>Control</i>	<i>Position</i>
DEV. MULT switch	XI
MODULATION	OFF
POWER	ON
FREQ. RANGE	100-200
DEVIATION	Approx. 5090 of rotation

(5) Set the controls of Electronic Counter AN/USM-207 as follows:

<i>Control</i>	<i>Position</i>
SENSITIVITY	PLUG-In
FUNCTION	FREQ
GATE TIME	10 ³
DISPLAY	Approx. 9 o'clock or as desired
POWER	STORE
Mixing Frequency Selector	100
Converter Attenuator Switches	Both to left
Direct/Heterodyne	Heterodyne

b. Initial Adjustments.

The following steps are performed to ensure that the output frequency of the signal generator matches the receiver frequency.

NOTE

The following steps should be performed approximately every ten minutes during receiver testing to ensure the signal generator remains set to the proper frequency.

(1) Adjust the output level of the signal generator so that the level meter of the electronic counter reads in the green area.

(2) Determine the frequency of the receiver from the nomenclature plate.

(3) Using the TUNING and TRIMMER controls of the signal generator, adjust the output so that the electronic counter display indicates the correct receiver frequency as determined in Step (2).

(4) Set the DIRECT/HETERODYNE switch to the HETERODYNE position.

c. Sensitivity Test.

(1) After performing the procedures in paragraph 3-4b. above, connect the test set as shown in Figure 3-3, using the rf cable and test cable #2.

(2) Set the MODULATION switch of the signal generator to the EXT. MOD position.

(3) Turn on the test set by setting its POWER switch to the ON position.

(4) Adjust the DEVIATION control of the signal generator so that the DEVIATION meter reads 12 kHz deviation on the yellow scale.

(5) Calibrate the OUTPUT control of the signal generator using the procedure described in the AN/URM-70 Signal Generator Manual, TM 11-1258.

(6) Adjust the OUTPUT control of the signal generator to 0.4 microvolt.

(7) Set the AREA switch of the receiver being tested to area #1 and make sure that the receiver is set to the DSPL mode.

(8) Set the data switches of the test set as follows: (See Figure 3-4).

SIGNAL GENERATOR AN/URM-70

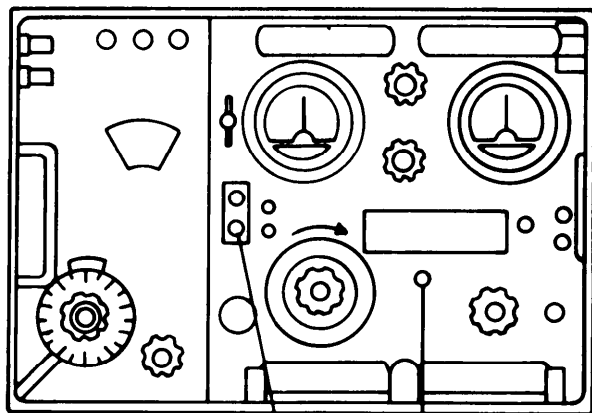

HEADSET

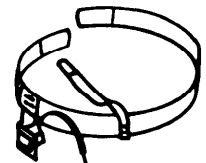

TEST CABLE NO.2

RF CABLE

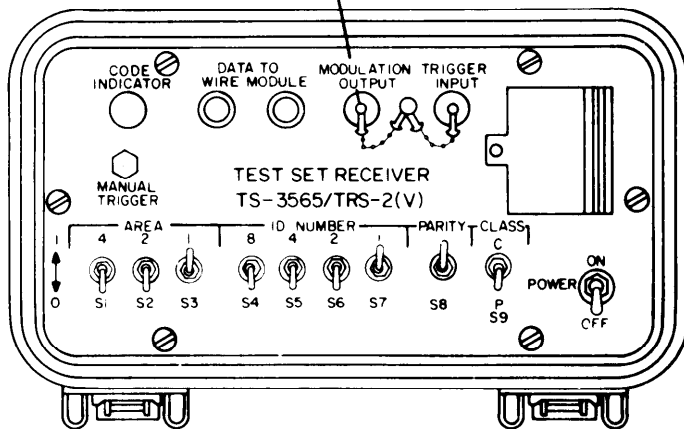

TEST SET

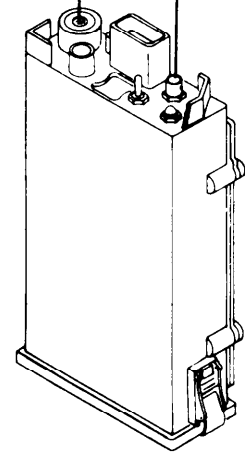

RECEIVER

EL5UL207

Figure 3-3. Receiver Sensitivity and Display Test Setup.

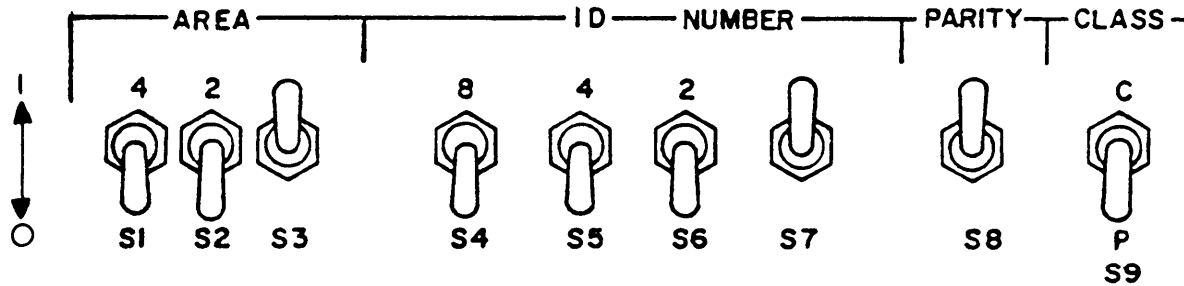

SWITCH SETTINGS FOR "001-0001-1-P"

Figure 3-4. Example data switch settings, Test Set, Receiver TRS-3565/TRS-2(V).

AREA	ID NUMBER	PARITY	CLASS
001	0001	1	P

NOTE

As indicated in Figure 3-4, the 0 condition is achieved by placing the designated toggle switch in the *down* position. The 1 condition is achieved by placing toggle switches in the *up*

position.

(9) Press the MANUAL-TRIGGER button on the test set and observe the display on the receiver. The display decimal points should momentarily light and the display should read *IP*.

d. Display Test.

(1) Adjust the output of the signal generator to 1 microvolt.

(2) Perform steps (a) and (b) below for each individual setting of the receiver AREA switch and test set data switches listed in Table 3-1.

Table 3-1. AREA SWITCH SETTINGS

Receiver AREA switch	Test Set Data Switches			
	AREA	ID NO.	PARITY	CLASS
2	010	0001	1	P
3	011	0001	0	P
4	100	0001	1	P
5	101	0001	0	P
6	110	0001	0	P
7	111	0001	1	P
8	000	0001	0	P

(a) Press the receiver TEST-RESET button.

(b) Press the test set MANUAL-TRIGGER button. For each AREA switch setting, the display on the receiver should read 1P.

(3) Set receiver AREA switch to position #1.

(4) Perform the following two steps for each individual setting of the test set data switches listed in Table 3-2. In each case, the display on the receiver should agree with the characters indicated in the table.

(a) Press the receiver TEST-RESET button.

(b) Press the test-set MANUAL-TRIGGER button. Check the characters on the receiver display against those specified above.

(5) After checking displays for all settings listed in

step (4), press the TEST-RESET button on the receiver.

(6) Press the MANUAL-TRIGGER button on the test set while watching the receiver display and listening to the earphone. The display should read 16C and decimal points should light on the display face momentarily. At the same time, the alert tone should be heard in the earphone.

(7) Press the TEST-RESET button on the receiver. The display should go blank.

(8) Turn the DSPL-TONE-OFF switch of the receiver to the TONE position.

(9) While listening to the earphone, press the MANUAL-TRIGGER button on the test set. The alert tone should be heard in the earphone.

Table 3-2. ID SWITCH SETTING

TEST SET DATA SWITCHES				RECEIVER DISPLAY
AREA	ID NO	PARITY	CLASS	
001	0001	1	P	1P
001	0001	1	C	1C
001	0010	1	P	2P
001	0010	1	C	2C
001	0011	0	P	3P
001	0011	0	C	3C
001	0100	1	P	4P
001	0100	1	C	4C
001	0101	0	P	5P
001	0101	0	C	5C
001	0110	0	P	6P
001	0110	0	C	6C
001	0111	1	P	7P
001	0111	1	C	7C
001	1000	1	P	8P
001	1000	1	C	8C
001	1001	0	P	9P
001	1001	0	C	9C
001	1010	0	P	10P
001	1010	0	C	10C
001	1011	1	P	11P
001	1011	1	C	11C
001	1100	0	P	12P
001	1100	0	C	12C
001	1101	1	P	13P
001	1101	1	C	13C
001	1110	1	P	14P
001	1110	1	C	14C
001	1111	0	P	15P
001	1111	0	C	15C
001	0000	0	P	16P
001	0000	0	C	16C

(10) Turn the DSPL-TONE-OFF switch of the receiver to the DSPL position. The display should read 16C.

(11) After completing the above tests, turn the POWER switches of all equipment to the OFF position and disconnect the rf cable and test cable #2.

NOTE

If an abnormal indication is observed during any of the steps, the receiver being tested can be assumed to be defective and should be forwarded to depot level repair personnel.

3-5. Troubleshooting Sensor Interface, Wire Link MX-9738/TRS-2(V)

The following test is performed to check the ability of

the wire link to pass input data to the receiver. The test set is utilized for this test.

a. Preliminary Procedure and Adjustments. Refer to paragraph 3-4 *a* and *b* for preliminary procedures and adjustments.

b. Wire Link Interface Test.

(1) Remove receiver battery compartment cover and install wire link on receiver.

(2) Connect the equipment as shown in Figure 3-5. Test cable #3 is connected to the No. 1 Terminals on the wire link. (Polarity of the wire is not important).

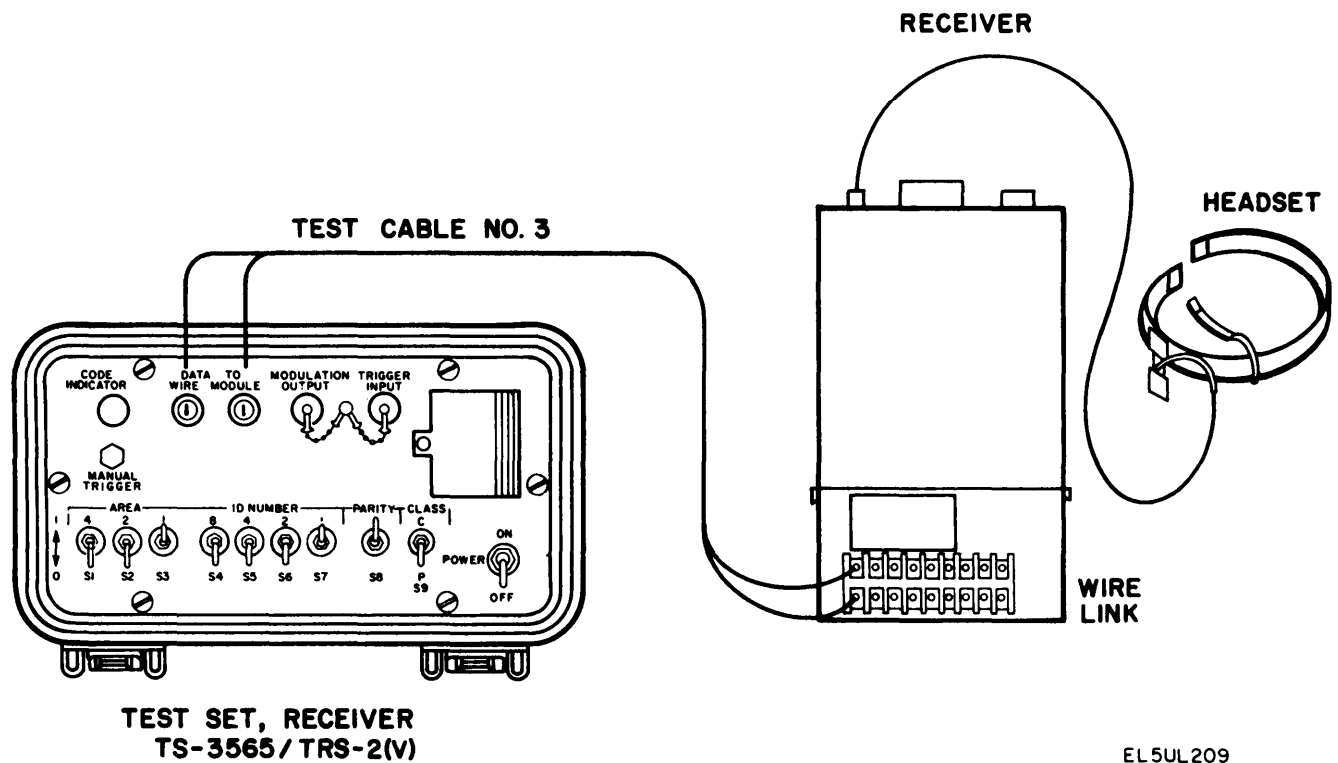

EL 5UL209

Figure 3-5. Wire Link Test Setup.

- (3) Set the wire link test switch to the REC position.
- (4) Set the AREA switch of the receiver to area No. 1.
- (5) Set the test set power ON-OFF switch to ON.
- (6) Set the data switches of the test set to read 001-0001-1-P and press the MANUAL-TRIGGER button on the test set. You should hear a tone in the headset, see the receiver LED display decimal points momentarily and see a display of 1P.
- (7) Turn off receiver and test set.
- (8) Remove the test cable connected to the No. 1

terminals of the wire link.

- (9) Repeat above procedures in steps (3) through (8) above to check terminals No. 2 through 9.

- (10) After completing the above tests, turn the power switches of all equipment to the OFF position and disconnect the test cable.

NOTE

If the receiver is found to be operating correctly in the RF mode but the proper display is not obtained during wire link mode testing, the wire link module can be assumed to be defective.

Section III. MAINTENANCE OF AN/TRS-2 (V) 1-6 (PEWS)

3-6. Maintenance of Detector, Anti-Intrusion DT -577(V)/TRS-2(V).

a. Encoding and Replacement of Detector Code Plug (Figure 3-6).

- (1) After it has been determined which AREA and ID numbers will be assigned to detectors, you must encode detector code plug and label detectors for future identification.

- (2) The code plug is divided into three separate sec-

tions corresponding to the different segments of the digital alarm message transmitted by the detector See Figure 3-6). The AREA number section of code PIU consists of three yellow wires; the ID number section consists of four green wires. An eighth wire (red) is used to determine the PARITY bit generated by the detector. These wires must be cut or left intact as necessary to encode the detector code plug with the desired AREA, ID and PARITY.

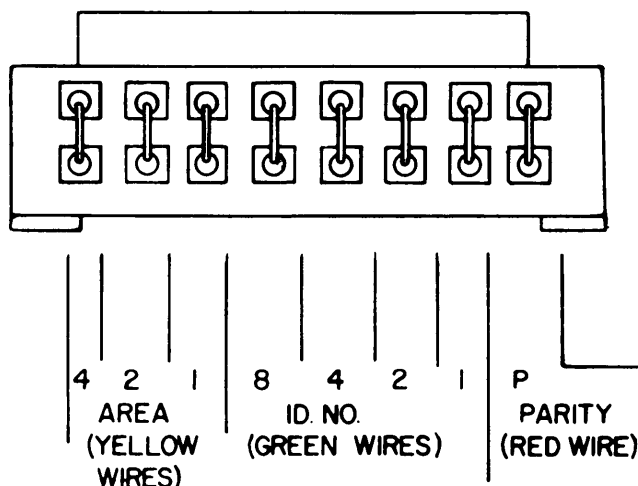

EL5UL010

Figure 3-6. Detector, Code Plug Assembly.

- (3) Perform the following procedure to encode the code plug:

- (a) Loosen the two knurled screws holding the detector battery cover in place.
- (b) Slide battery cover open to expose detector battery.
- (c) Remove detector battery.
- (d) Carefully remove old code plug by unplugging it from the receptacle in the battery compartment.

ing it from the receptacle in the battery compartment.

- (e) To encode AREA number, refer to Figure 3-7 to determine which YELLOW wires on the new coal plug should be cut away to give the proper AREA number. Using a small pair of diagonal cutters, carefully cut and remove the indicated YELLOW wires from the code plug.

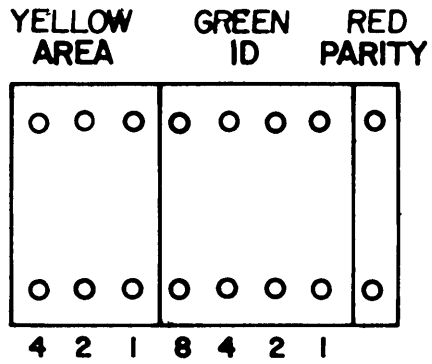

I. AREA CODING - YELLOW

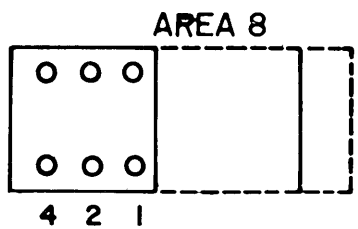
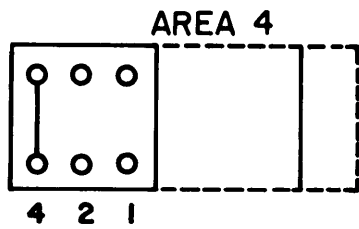
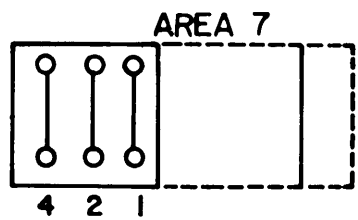
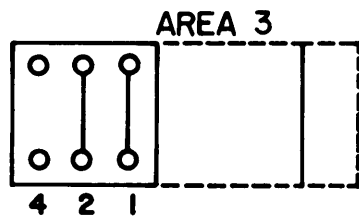
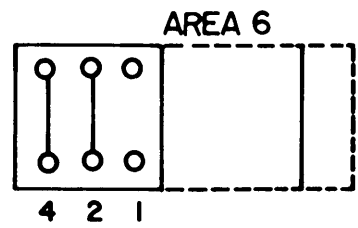
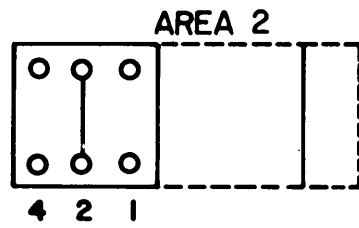
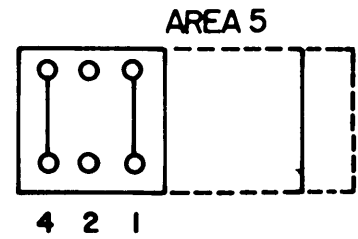
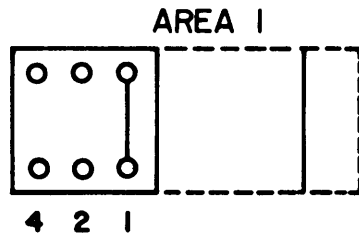

Figure 3-7. Code Plug AREA Connections.

NOTE

When removing code plug wires, be sure to cut away *both* ends of wire being removed. This minimizes the possibility of short circuits and detector malfunction.

(f) To encode ID number, refer to Figure 3-8 to determine which GREEN wires on the new code plug should be cut away to give the proper ID number. Using the diagonal cutters, cut away both ends of the indicated GREEN wires from the code plug.

(g) To encode parity, count the total of wires still present in the yellow and green sections of the code plug. If there is an even (0, 2, 4, 6) number of wires remaining, leave the parity (RED) wire in place. If there is an *uneven* (1, 3, 5, 7) number remaining, cut away both ends of the RED wire from the code plug.

(h) Carefully insert newly-cut code plug into receptacle in detector battery compartment.

(i) On detector writing surface (located on inside of battery cover), write the new AREA and ID numbers of the detector.

(j) Reinstall detector battery.

(k) Close battery cover and tighten knurled screw.

(l) Perform pre-mission detector checks as described in Chapter 2, of TM 11-5895-1047-10 to verify that you have correctly encoded the code plug.

b. Removal and Replacement of Detector Battery Connector.

(1) Loosen the two knurled screws holding battery cover assembly and open cover.

(2) Remove screw holding battery connector nylon tether to connector.

(3) Unplug battery connector plug from receptacle in battery compartment.

(4) Plug new battery connector plug into receptacle in battery compartment.

(5) Anchor nylon tether cord to detector by replacing screw and tightening.

(6) Reinstall detector battery.

(7) Close battery cover and tighten knurled screws.

(8) Perform pre-mission checks as described in Chapter 2 of TM 11-5895-1047-10.

c. Removal and Replacement of Battery Cover Assembly and Writing Surface.

(1) Remove the two knurled screws holding the battery cover in place.

(2) Remove battery cover from detector.

(3) Prepare new battery cover assembly for installation by placing a new writing surface inside of battery cover.

(4) To install writing surface peel back protective

cover and carefully position in place.

(5) Position new cover on detector and fasten with the hardware removed in step (1).

3-7. Maintenance of Receiver, Radio R-1808(V)/TRS-2(V)

a. Removal and Replacement of Receiver AREA Selection Knob.

(1) Rotate area selection knob to expose allen screws.

(2) Loosen allen screws on area selection knob.

(3) Remove area selection knob.

(4) Install new area selection knob.

(5) Tighten allen screws.

b. Removal and Replacement of LED Rubber Boot.

(1) Remove unserviceable LED boot from receiver by cutting at base of boot with a knife.

WARNING

Adequate ventilation should be provided while using TRICHLOROTRIFLUOROETHANE. Prolonged breathing of vapor should be avoided. The solvent should not be used near heat or open flame; the products of decomposition are toxic and irritating. Since TRICHLOROTRIFLUOROETHANE dissolves natural oils, prolonged contact with skin should be avoided. When necessary, use gloves which the solvent cannot penetrate. If the solvent is taken internally, consult a physician immediately.

(2) Use a cloth, item 1, appendix C, moistened with TRICHLOROTRIFLUOROETHANE to clean surface from which boot was removed.

(3) Wipe surface dry with a clean lint-free cloth. Do not allow lint or foreign matter to remain on surface.

(4) Cement new LED boot to receiver LED housing with General Purpose Adhesive, item 3, appendix C.

c. Removal and Replacement of Writing Surface.

(1) To remove unserviceable writing surface, peel old surface from receiver.

(2) Use a cloth moistened with TRICHLOROTRIFLUOROETHANE, item 2, appendix C to clean surface of receiver.

(3) Wipe surface dry with a clean lint-free cloth. Do not allow lint or foreign matter to remain on surface.

(4) To install new writing surface, peel back protective covering and carefully position in place.

d. Deleted.

e. Removal and Replacement of Battery Cover and Gasket.

(1) Remove nylon cord holding battery cover to latch.

ID CODING - GREEN

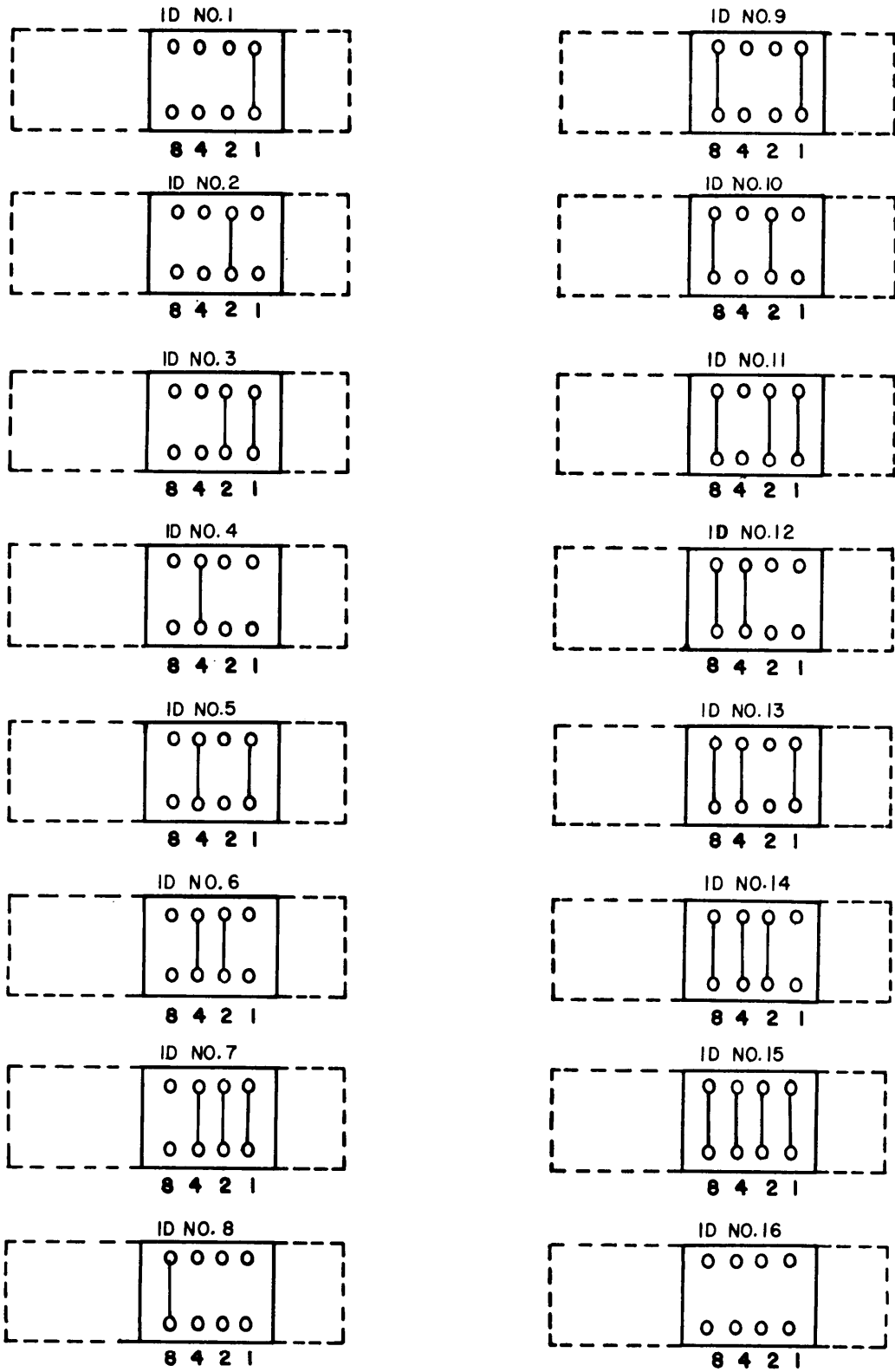

EL5ULOI2

Figure 3-8. Code Plug ID connection.

(2) Unfasten latches holding cover and remove cover.

(3) Position new cover on the receiver and latch.

(4) Loop new nylon cord (4 inches) through holes on latch and cover. Knot end of cord at latch.

(5) Knot remaining end of cord. Be sure that there is enough slack in cord to allow cover to be positioned properly when opened.

(6) Coat knotted ends of cord with General Purpose Adhesive, item 3, appendix C to keep them from unraveling.

f. Removal and Replacement of Receiver Battery Connector.

(1) Unfasten latches holding battery cover assembly and open cover.

(2) Remove screw holding battery connector nylon tether to receiver.

(3) Unplug battery connector plug from receptacle in battery compartment.

(4) Plug new battery connector plug into receptacle in battery compartment.

(5) Anchor nylon tether cord to receiver by replacing screw and tightening.

(6) Reinstall batteries in receiver, close cover and latch.

(7) Perform permission checks as described in Chapter 2 of TM 11-5895-1047-10.

g. Replacement of Receiver Carrying Rings.

(1) Insert new carrying ring through hole on top of receiver (near front panel assembly).

(2) Press ends of carrying ring together with pair of pliers. Carrying ring should move freely.

3-8. Maintenance of Sensor Interface, Wire Link MX-9738/TRS-2(V).

To remove and replace the wire link REC-TEST switch knob, follow the procedures below:

a. Rotate knob to expose allen screws.

b. Loosen allen screws from the knob.

c. Remove knob.

d. Install new knob.

e. Tighten allen screws removed in step *b.* above.

Section IV. DIRECT SUPPORT TESTING PROCEDURES

3-9. Permission Tests.

Permission testing of the AN/TRS-2(V) is listed in Chapter 2 of TM 11-5895-1047-10. The only Direct Support final test is the acceptance test performed on the detector. This test verifies the output of the newly cut code plug.

3-10. Detector, Anti-Intrusion DT-577(V)/TRS-2(V) Acceptance Test.

a. Remove the code plug from the battery compartment of the detector under test and insert the newly cut code plug.

b. Perform receiver permission test to ensure that receiver is operational.

c. Perform detector permission test (RF mode) to verify that you have correctly encoded the newly cut code plug.

d. Turn off receiver and detector.

APPENDIX A REFERENCES

DA PAM 310-4	Index of Technical Publications.
SB 11-573	Painting and Preservation Supplies Available for Field Use for Electronics Command Equipment.
3B 38-100	Preservation, Packaging, Packing, and Marking Materials, Supplies, and Equipment Used by the Army.
TB 43-0118	Field Instructions for Painting and Preserving Electronics Command Equipment Including Camouflage Pattern Painting of Electrical Equipment Shelters.
TM 11-1258	Signal Generator AN/URM-70.
TM 11-5895-1047-10	Operator's Manual for Platoon Early Warning Systems AN/TRS-2(V)1 (NSN 5895-01-063-8103), AN/TRS-2(V)2 (NSN 5895-01-073-9032), AN/TRS-2(V)3 (NSN 5895-01-063-8104), AN/TRS-2(V)4 (NSN 5895-01-068-6747), AN/TRS-2(V)5 (NSN 5895-01-068-6748) and AN/TRS-2(V)6 (NSN 5895-01-068-6749).
TM 11-5895-1047-23	Organizational and Direct Support Maintenance Manual for Platoon Early Warning System AN/TRS-2(V)1 (NSN 5895-01-063-8103), AN/TRS-2(V)2 (NSN 5895-01-073-9032), AN/TRS-2(V)3 (NSN 5895-01-063-8104), AN/TRS-2(V)4 (NSN 5895-01-068-6747), AN/TRS-2(V)5 (NSN 5895-01-068-6748), and AN/TRS-2(V)6 (NSN 5895-01-068-6749).
TM 11-6625-366-15	Operator's, Organizational, Direct Support, General Support and Depot Maintenance Manual: Multimeter TS-352B/U (NSN 6625-00-553-0142).
TM 11-6625-700-10	Operator's Manual: Digital Readout, Electronic Counter AN/USM-207 (NSN 6625-00-911-6368).
TM 11-6625-2658-14	Operator's, Organizational, Direct Support and General Support Maintenance Manual for Oscilloscope, AN/USM-281C (NSN 6625-00-106-22).
TM 11-6625-2784-24P	Organizational, Direct Support, and General Support Maintenance Repair Parts And Special Tools List (Including Depot Maintenance Repair Parts and Special Tools) for Test Set, TS-3565/TRS-2 (NSN 6625-01-075-0046).
TM 38-750	The Army Maintenance Management System (TAMMS).
TM 750-244-2	Procedures for Destruction of Electronics Materiel to Prevent Enemy Use (Electronics Command).

APPENDIX B

MAINTENANCE ALLOCATION

Section I. INTRODUCTION

B-1. General.

This appendix provides a summary of the maintenance operations for Platoon Early Warning System AN/TRS-2(V) through 6. It authorizes categories of maintenance for specific maintenance functions on repairable items and components and the tools and equipment required to perform each function. This appendix may be used as an aid in planning maintenance operations.

B-2. Maintenance Function.

Maintenance functions will be limited to and defined as follows:

a. Inspect. To determine the serviceability of an item by comparing its physical, mechanical, and/or electrical characteristics with established standards through examination.

b. Test. To verify serviceability and to detect incipient failure by measuring the mechanical or electrical characteristics of an item and comparing those characteristics with prescribed standards.

c. Service. Operations required periodically to keep an item in proper operating condition, i.e., to clean (decontaminate), to preserve, to drain, to paint, or to replenish fuel, lubricants, hydraulic fluids, or compressed air supplies.

d. Adjust. To maintain, within prescribed limits, by bringing into proper or exact position, or by setting the operating characteristics to the specified parameters.

e. Align. To adjust specified variable elements of an item to bring about optimum or desired performance.

f. Calibrate. To determine and cause corrections to be made or to be adjusted on instruments or test measuring and diagnostic equipments used in precision measurement. Consists of comparisons of two instruments, one of which is a certified standard of known accuracy, to detect and adjust any discrepancy in the accuracy of the instrument being compared.

g. Install. The act of emplacing, seating, or fixing into position an item, part, module (component or assembly) in a manner to allow the proper functioning of the equipment or system.

h. Replace. The act of substituting a serviceable like type part, subassembly, or module (component or assembly) for an unserviceable counterpart.

i. Repair. The application of maintenance services (inspect, test, service, adjust, align, calibrate, replace) or other maintenance actions (welding, grinding, riveting, straightening, facing, remachining or resurfac-

ing) to restore serviceability to an item by correcting specific damage, fault, malfunction, or failure in a part, subassembly, module (component or assembly), end item, or system.

j. Overhaul. That maintenance effort (service/action) necessary to restore an item to a completely serviceable/operational condition as prescribed by maintenance standards (i.e., DMWR) in appropriate technical publications. Overhaul is normally the highest degree of maintenance performed by the Army. Overhaul does not normally return an item to like new condition.

k. Rebuild. Consists of those services/actions necessary for the restoration of unserviceable equipment to a like new condition in accordance with original manufacturing standards. Rebuild is the highest degree of materiel maintenance applied to Army equipment. The rebuild operation includes the act of returning to zero those age measurements (hours, miles, etc.) considered in classifying Army equipments/components.

B-3. Column Entries.

a. Column 1, Group Number. Column 1 lists group numbers, the purpose of which is to identify components, assemblies, subassemblies, and modules with the next higher assembly.

b. Column 2, Component/Assembly. Column 2 contains the noun names of components, assemblies, subassemblies, and modules for which maintenance is authorized.

c. Column 3, Maintenance Functions. Column 3 lists the functions to be performed on the item listed in column 2. When items are listed without maintenance functions, it is solely for purpose of having the group numbers in the MAC and RPSTL coincide.

d. Column 4, Maintenance Category. Column 4 specifies, by the listing of a "work time" figure in the appropriate subcolumn(s), the lowest level of maintenance authorized to perform the function listed in column 3. This figure represents the active time required to perform that maintenance function at the indicated category of maintenance. If the number or complexity of the tasks within the listed maintenance function vary at different maintenance categories, appropriate "work time" figures will be shown for each category. The number of task-hours specified by the "work time" figure represents the average time required to restore an item (assembly, subassembly, component, module, end item or system) to a serviceable condition under typical field operating conditions. This time includes preparation time, troubleshooting time, and

quality assurance/quality control time in addition to the time required to perform the specific tasks identified for the maintenance functions authorized in the maintenance allocation chart. Subcolumns of column 4 are as follows:

- C-Operator/Crew
- O-Organizational
- F-Direct Support
- H-General Support
- D-Depot

e. Column 5, Tools and Equipment. Column 5 specifies by code, those common tool sets (not individual tools) and special tools, test, and support equipment required to perform the designated function.

f. Column 6, Remarks. Column 6 contains an alphabetic code which leads to the remark in section IV, Remarks, which is pertinent to the item opposite the particular code.

B-4. Tool and Test Equipment Requirements (Sect. III).

a. Tool or Test Equipment Reference Code. The numbers in this column coincide with the numbers used

in the tools and equipment column of the MAC. The numbers indicated the applicable tool or test equipment for the maintenance functions.

b. Maintenance Category. The codes in this column indicate the maintenance category allocated the tool or test equipment.

c. Nomenclature. This column lists the noun name and nomenclature of the tools and test equipment required to perform the maintenance functions.

d. National/NATO Stock Number. This column lists the National/NATO stock number of the specific tool or test equipment.

e. Tool Number. This column lists the manufacturer's part number of the tool followed by the Federal Supply Code for manufacturers (5-digit) in parentheses.

B-5. Remarks (Sect. IV).

a. Reference Code. This code refers to the appropriate item in section II, column 6.

b. Remarks This column provides the required explanatory information necessary to clarify items appearing in section II.

(Next printed page is B-3)

SECTION II MAINTENANCE ALLOCATION CHART
FOR

PLATOON EARLY WARNING SYSTEM AN/ TRS-2(V)*

(1) GROUP NUMBER	(2) COMPONENT ASSEMBLY	(3) MAINTENANCE FUNCTION	(4) MAINTENANCE CATEGORY					(5) TOOLS AND EQPT.	(6) REMARKS
			C	O	F	H	D		
00	PLATOON EARLY WARNING SYSTEM AN/TRS-2(V)*	Inspect Service Test Install Repair	0.1 0.1 0.2 0.5 0.1					1 1	A B
01	RECEIVER, RADIO R-1808(V)*/TRS-2(V)	Inspect Test Test Test Repair Repair Repair	0.1 0.3		0.1 1.0 0.2		0.7 1.6	3 thru 6 2,3,4,7,8 2 2,7	C D E F G H
	CIRCUIT CARD ASSEMBLY, DISPLAY (2A1) SM-D-783163	Inspect Test Replace					0.1 0.5 0.2	2,5 thru 8, 10, 11 2	
	CIRCUIT CARD ASSEMBLY, DECODER (2A2) SM-D-783167	Inspect Test Replace					0.1 0.5 0.2	2, 5 thru 9 2	
	CIRCUIT CARD ASSEMBLY, RF (2A3) SM-D-783191-1 thru -6	Inspect Test Align Replace					0.1 0.5 0.2 0.2	2,6,7,8,14,15 7 2	
02	DETECTOR, ANTI-INTRUSION DT-577(V)*/TRS-2(V)	Inspect Test Test Test Repair Repair	0.2 0.2		0.1 0.3 1.0		1.0	5 2,6,7,8,16 thru 19,21, 22,24,25,26, 28,31	I J
03	SENSOR INTERFACE, WIRE LINK MX-9738/TRS-2(V)	Inspect Test Test Test Repair	0.1		0.1 0.1 0.2		0.5	2 2,5,7,8,10, 21,29,30 2	K L M N
04	CASE, PLATOON EARLY WARNING SYSTEM CY-7524/TRS-2(V)	Inspect Repair Replace	0.1 0.1		0.5			2	O P
	* ALL VARIATIONS								

SECTION III TOOL AND TEST EQUIPMENT REQUIREMENTS
FOR

PLATOON EARLY WARNING SYSTEM AN/TRS-2(V)*

TOOL OR TEST EQUIPMENT REF CODE	MAINTENANCE CATEGORY	NOMENCLATURE	NATIONAL/NATO STOCK NUMBER	TOOL NUMBER
1	C	TOOL KIT TE-33	5180-00-408-1859	
2	F,D	TOOL KIT, ELECTRONIC EQUIPMENT TK-105/G	5180-00-610-8177	
3	F,D	TEST SET TS-3565/TRS-2	6625-01-075-0046	
4	F,D	SIGNAL GENERATOR AN/URM-70	6625-00-519-2104	
5	F,D	MULTIMETER TS-352B/U	6625-00-553-0142	
6	F,D	COUNTER, ELECTRONIC, DIGITAL READOUT AN/USM-207A	6625-00-044-3228	
7	D	POWER SUPPLY HP-721		
8	D	DIGITAL VOLTMETER AN/GSM-64B		
9	D	DECODER TEST FIXTURE		
10	D	FUNCTION GENERATOR (WAVETEK 184)		
11	D	MEMORY/DISPLAY CIRCUIT BOARD TEST FIXTURE		
12	D	RF GENERATOR HP-8640B		
13		DELETED		
14	D	RF VOLTMETER (BOONTON 91AD)		
15	D	RF CIRCUIT BOARD TEST FIXTURE		
16	D	PULSE GENERATOR HP8011A		
17	D	ATTENUATOR CN-970/U		
18	D	ATTENUATOR CN-1130/U		
19	D	NOISE GENERATOR (WAVETEK 132)		
20		DELETED		
21	D	OSCILLOSCOPE AN/USM-281C		
22	D	MAGNETIOMETER (RFL 101)		
23		DELETED		
24	D	HELMHOLTZ COIL		
25	D	ATTENUATOR HP-8495A		
26	D	POWER METER HP-432A		
27		DELETED		
28	D	SPECTRUM ANALYZER HP-88552B		
29	D	DECADE RESISTOR (HEATH IN-3117)		
30	D	WIRE LINK TEST FIXTURE		
31	D	TARGET DETECTION TEST FIXTURE		
		* ALL VARIATIONS		

SECTION IV. REMARKS

REFERENCE CODE	REMARKS
A	OPERATIONAL TEST. CHECK RF AND WIRE LINK FOR PROPER OPERATON.
B	REPAIR BY REMOVAL/REPLACEMENT OF MAJOR COMPONENTS.
C	PREOPERATIVE TEST.
D	DISPLAY TEST AND SENSITIVITY TEST.
E	TEST OF PANEL SWITCHES AND CONNECTORS.
F	REPAIR BY REMOVAL/REPLACEMENT OF BATTERIES, HEADSET, ANTENNA, CARRYING STRAPS, AND GROUND STAKE.
G	REPAIR BY REMOVAL/REPLACEMENT OF BATTERY COVER, KNOBS, WRITING SURFACE, GASKETS, AND BATTERY CONNECTOR.
H	REPAIR BY REMOVAL/REPLACEMENT OF HEADSET CONNECTOR RECEPTACLE, SWITCHES, LED DISPLAY LENS, HEADSET, CONNECTOR, CIRCUIT BOARDS (PLUG-IN INSTALLATION), AND CASE.
I	PREOPERATIVE TESTS IN RF AND WIRE LINK MODES.
J	TEST DETECTOR OPERATION BY CHECKING CURRENT DRAIN.
K	REPAIR BY REMOVAL/REPLACEMENT OF BATTERY, ANTENNA, AND GROUND STAKE.
L	REPAIR BY REMOVAL/REPLACEMENT OF CODE PLUG ASSEMBLY, WRITING SURFACES, BATTERY CONNECTOR, BATTERY COVER, KNURLED SCREWS, GASKET, AND BATTERY PLUG ASSEMBLY.
M	PREOPERATIVE TEST.
N	TEST USING INTRODUCTION OF DATA TO LINK.
O	REPAIR BY REMOVAL/REPLACEMENT OF KNOB, GROUND LEAD, TERMINAL SCREWS, AND GASKET.
P	REPAIR BY REMOVAL/REPLACEMENT OF "D" RINGS, STRAPS AND ACCESSORY EQUIPMENT CASE.

APPENDIX C

EXPENDABLE SUPPLIES AND MATERIALS LIST

Section I. INTRODUCTION

C-1. Scope

This appendix lists expendable supplies and materials you will need to operate and maintain the Platoon Early Warning System AN/TRS-2 (V) 1 through 6. These items are authorized to you by CTA 50-970, Expendable Items (Except Medical, Class V, Repair Parts, and Heraldic Items).

C-2. Explanation of Columns

a. Column 1-Item number. This number is assigned to the entry in the listing and is referenced in the narrative instructions to identify the material (e.g., "Use cleaning compound, item 5, App. D").

b. Column 2-Level This column identifies the lowest level of maintenance that requires the listed item.

C - Operator/Crew

O - Organizational Maintenance/Aviation Unit Maintenance

F - Direct Support Maintenance/Aviation Intermediate Maintenance

H - General Support Maintenance

c. Column 3-National Stock Number. This is the National stock number assigned to the item; use it to request or requisition the item.

d. Column 4-Description. Indicates the Federal item name and, if required, a description to identify the item. The last line for each item indicates the Federal Supply Code for Manufacturer (FSCM) in parentheses followed by a part number.

e. Column 5- Unit of Measure (U/M). Indicates the measure used in performing the actual maintenance function. This measure is expressed by a two-character alphabetical abbreviation (e.g., ea, in, pr). If the unit of measure differs from the unit of issue, requisition the lowest unit of issue that will satisfy your requirements.

(Next printed page is C-3)

SECTION II EXPENDABLE SUPPLIES AND MATERIALS LIST

(1) ITEM NO.	(2) LEVEL	(3) NATIONAL STOCK NUMBER	(4) DESCRIPTION PART NO. AND FSCM	(5) UNIT OF MEAS
1	F	8305-00-222-2423	CLOTH, LINT FREE (81348) CC-C-440	YD
2	F	6850-00-984-5853	TRICHLOROTRIFLUOROETHANE, CLEANING COMPOUND FREON PCA (81349) MIL-C-81302	GAL
3	F		ADHESIVE GENERAL PURPOSE TYPE I CLASS I (81349) MIL-A-46050	QT

By Order of the Secretary of the Army:

EDWARD C. MEYER
General, United States Army
Chief of Staff

Official:

J. C. PENNINGTON
Major General, United States Army
The Adjutant General

DISTRIBUTION:

Active Army

HISA (Ft Monmouth) (21)	USARMIS (1)
USAINSCOM (2)	USAES (2)
COE (1)	USAICS (3)
TSG (1)	MAAG (1)
USAARENBD (1)	USAERDAW (1)
DARCOM (1)	USAERDW (1)
TRADOC (2)	Ft Gordon (10)
OS Maj Cmd (4)	Ft Carson (5)
TECOM (2)	Army Dep (1) except
USACC (4)	SAAD (30)
MDW (1)	TOAD (14)
Armies (2)	SHAD (2)
Corps (2)	Ft Gillem (10)
Svc Colleges (1)	USA Dep (1)
USASIGS (5)	Sig Sec USA Dep (1)
USAADS (2)	Ft Richardson (CERCOM Oft) (2)
USAFAS (2)	Units org under fol TOE:
USMMS (2)	29-207 (2)
USAIS (2)	29-610 (2)

NG: None

USAR: None

For explanation of abbreviations used, see AR 31050.

RECOMMENDED CHANGES TO EQUIPMENT TECHNICAL PUBLICATIONS



THEN... JOT DOWN THE DOPE ABOUT IT ON THIS FORM. CAREFULLY TEAR IT OUT, FOLD IT AND DROP IT IN THE MAIL!

SOMETHING WRONG WITH THIS PUBLICATION?

FROM (PRINT YOUR UNIT'S COMPLETE ADDRESS)
 Commander
 Stateside Army Depot
 ATTN: AMSTA-US
 Stateside, N.J. 07703

DATE SENT
 10 July 1975

PUBLICATION NUMBER
 TM 11-5840-340-12

PUBLICATION DATE
 23 Jan 74

PUBLICATION TITLE
 Radar Set AN/PRC-76

BE EXACT PIN-POINT WHERE IT IS

PAGE NO	PARA-GRAPH	FIGURE NO	TABLE NO
2-25	2-28		
3-10	3-3	3-1	
5-6	5-8		

IN THIS SPACE TELL WHAT IS WRONG AND WHAT SHOULD BE DONE ABOUT IT:

Recommend that the installation antenna alignment procedure be changed throughout to specify a 2° IFF antenna lag rather than 1°.

REASON: Experience has shown that with only a 1° lag, the antenna servo system is too sensitive to wind gusting in excess of 25 knots, and has a tendency to rapidly accelerate and decelerate as it hunts, causing strain to the drive train. Hunting is minimized by adjusting the lag to 2° without degradation of operation.

Item 5, Function column. Change "2 db" to "3db."

REASON: The adjustment procedure the the TRANS POWER FAULT indicator calls for a 3 db (500 watts) adjustment to light the TRANS POWER FAULT indicator.

Add new step f.1 to read, "Replace cover plate removed in step e.1, above."

REASON: To replace the cover plate.

Zone C 3. On J1-2, change "+24 VDC to "+5 VDC."

REASON: This is the output line of the 5 VDC power supply. +24 VDC is the input voltage.

PRINTED NAME GRADE OR TITLE AND TELEPHONE NUMBER
 SSG I. M. DeSpirito 999-1776

SIGN HERE

TEAR ALONG PERFORATED LINE

RECOMMENDED CHANGES TO EQUIPMENT TECHNICAL PUBLICATIONS



THEN... JOT DOWN THE DOPE ABOUT IT ON THIS FORM. CAREFULLY TEAR IT OUT, FOLD IT AND DROP IT IN THE MAIL!

SOMETHING WRONG WITH THIS PUBLICATION?

FROM (PRINT YOUR UNIT'S COMPLETE ADDRESS)

DATE SENT

PUBLICATION NUMBER

TM 11-5895-1047-23

PUBLICATION DATE

PUBLICATION TITLE **Platoon Early Warning System AN/TRS-2(V)1 through 6**

BE EXACT PIN-POINT WHERE IT IS

PAGE NO	PARA-GRAPH	FIGURE NO	TABLE NO

IN THIS SPACE TELL WHAT IS WRONG AND WHAT SHOULD BE DONE ABOUT IT:

PRINTED NAME, GRADE OR TITLE AND TELEPHONE NUMBER

SIGN HERE

DA FORM 2028-2
1 JUL 79

PREVIOUS EDITIONS ARE OBSOLETE

PLEASE IF YOUR OUTFIT WANTS TO KNOW ABOUT YOUR RECOMMENDATION MAKE A CARBON COPY OF THIS AND GIVE IT TO YOUR HEADQUARTERS

FILL IN YOUR
UNIT'S ADDRESS

FOLD BACK

DEPARTMENT OF THE ARMY

POSTAGE AND FEES PAID
DEPARTMENT OF THE ARMY
DOD 314



OFFICIAL BUSINESS
PENALTY FOR PRIVATE USE \$300

TEAR ALONG PERFORATED LINE

Commander
US Army Communications and
Electronics Materiel Readiness Command
ATTN: DRSEL-ME-MQ
Fort Monmouth, New Jersey 07703

The Metric System and Equivalents

Linear Measure

1 centimeter = 10 millimeters = .39 inch
 1 decimeter = 10 centimeters = 3.94 inches
 1 meter = 10 decimeters = 39.37 inches
 1 dekameter = 10 meters = 32.8 feet
 1 hectometer = 10 dekameters = 328.08 feet
 1 kilometer = 10 hectometers = 3,280.8 feet

Weights

1 centigram = 10 milligrams = .15 grain
 1 decigram = 10 centigrams = 1.54 grains
 1 gram = 10 decigrams = .035 ounce
 1 dekagram = 10 grams = .35 ounce
 1 hectogram = 10 dekagrams = 3.52 ounces
 1 kilogram = 10 hectograms = 2.2 pounds
 1 quintal = 100 kilograms = 220.46 pounds
 1 metric ton = 10 quintals = 1.1 short tons

Liquid Measure

1 centiliter = 10 milliliters = .34 fl. ounce
 1 deciliter = 10 centiliters = 3.38 fl. ounces
 1 liter = 10 deciliters = 33.81 fl. ounces
 1 dekaliter = 10 liters = 2.64 gallons
 1 hectoliter = 10 dekaliters = 26.42 gallons
 1 kiloliter = 10 hectoliters = 264.18 gallons

Square Measure

1 sq. centimeter = 100 sq. millimeters = .155 sq. inch
 1 sq. decimeter = 100 sq. centimeters = 15.5 sq. inches
 1 sq. meter (centare) = 100 sq. decimeters = 10.76 sq. feet
 1 sq. dekameter (are) = 100 sq. meters = 1,076.4 sq. feet
 1 sq. hectometer (hectare) = 100 sq. dekameters = 2.47 acres
 1 sq. kilometer = 100 sq. hectometers = .386 sq. mile

Cubic Measure

1 cu. centimeter = 1000 cu. millimeters = .06 cu. inch
 1 cu. decimeter = 1000 cu. centimeters = 61.02 cu. inches
 1 cu. meter = 1000 cu. decimeters = 35.31 cu. feet

Approximate Conversion Factors

To change	To	Multiply by	To change	To	Multiply by
inches	centimeters	2.540	ounce-inches	newton-meters	.007062
feet	meters	.305	centimeters	inches	.394
yards	meters	.914	meters	feet	3.280
miles	kilometers	1.609	meters	yards	1.094
square inches	square centimeters	6.451	kilometers	miles	.621
square feet	square meters	.093	square centimeters	square inches	.155
square yards	square meters	.836	square meters	square feet	10.764
square miles	square kilometers	2.590	square meters	square yards	1.196
acres	square hectometers	.405	square kilometers	square miles	.386
cubic feet	cubic meters	.028	square hectometers	acres	2.471
cubic yards	cubic meters	.765	cubic meters	cubic feet	35.315
fluid ounces	milliliters	29.573	cubic meters	cubic yards	1.308
pints	liters	.473	milliliters	fluid ounces	.034
quarts	liters	.946	liters	pints	2.113
gallons	liters	3.785	liters	quarts	1.057
ounces	grams	28.349	liters	gallons	.264
pounds	kilograms	.454	grams	ounces	.035
short tons	metric tons	.907	kilograms	pounds	2.205
pound-feet	newton-meters	1.356	metric tons	short tons	1.102
pound-inches	newton-meters	.11296			

Temperature (Exact)

°F Fahrenheit temperature 5/9 (after subtracting 32) Celsius temperature °C

